



**Phoenix<sup>TM</sup>**  
Phoenix Temperature Measurement

# HTS12 Systems

For heat treatment processes  
with integrated oil quench



*...where experience counts !*

# Phoenix™ HTS12 Systems

Temperature monitoring of integrated oil quench furnaces

## Data Logger

Phoenix™ data loggers are designed for use in harsh industrial environments. The electronics are protected by a robust, water resistant, machined aluminum case. Cold junction compensation with feedback error detection and noise reduction ensures accurate and reliable data. Optional two way RF telemetry is available, allowing real time data analysis and for the data logger to be reset and downloaded remotely. All loggers are shipped with a factory calibration certificate traceable to national standards. Optional certification to UKAS (UK) or DKD (Germany) can be supplied if required. For convenience and future reference, a copy of the original calibration certificate and the calibration data are stored within the data logger and can be accessed as required.

Type	PTM1-206, PTM1-210, PTM1-220	
No. of channels	6, 10 or 20	
Thermocouple type	K or N	
Measurement range		
Type K:	-148°F - +2498°F	-100°C - +1370°C
Type N:	-148°F - +2372°F	-100°C - +1300°C
Accuracy	± 0.5°F	± 0.3°C
Resolution	0.2°F	0.1°C
Max operating temperature	176°F	80°C
Battery type	2 x Standard Alkaline (AA)	
Sampling rate	Adjustable from 0.2 second to 1 hour	
Memory	Up to 3.8M data points, non-volatile memory	
Start trigger	Start button, time, temperature or software	
Dimensions	0.79"x3.85"x7.87"(h x w x l) 20 x 98 x 200mm	

Bluetooth PC connection



Optional two way radio transmission from the hot zone



Robust and waterproof housing for reliable use in hostile environments



Up to 1000 hours measurement time



## Thermocouples

For temperatures from 250°C to more than 1000°C mineral insulated thermocouples are generally the first choice. The thermocouples wires are insulated by magnesium oxide and protected by a high grade alloy sheath. For special applications we can supply thermocouples with other insulation materials.

Thermocouples can be welded, mechanically held, or retained in holes to record temperatures at critical points.



Type K or N mineral insulated thermocouples in 1.5 and 2.0mm diameter.





## TS12 Thermal Barriers

Carburizing in an integrated quench (IQ) furnace is a common heat treatment process for the manufacture of gears, etc., and oil is the most commonly used quench medium. During the oil quench, products within the batch can sometimes experience distortion problems, which may have several causes including flow patterns, temperature variations, etc.

Monitoring the temperature at various depths within the product and locations around the batch, can provide valuable data on the temperature profile of the part throughout the complete heating and cooling cycle. However monitoring part temperature from a data logger external to the furnace is not possible, so the PhoenixTM Oil Quench system, which is able to travel throughout the process with the products, is the answer.

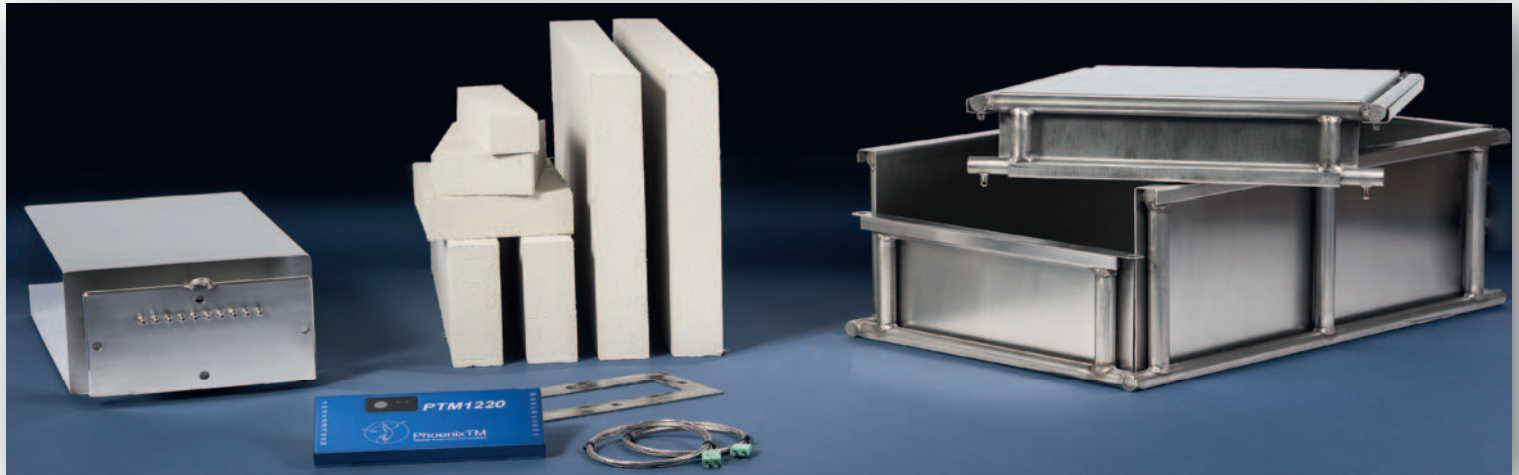

Type	TS12-200	TS12-250	TS12-300
1110°F (600°C) / h	3.4	6.0	8.0
1470°F (800°C) / h	2.4	4.0	5.7
1652°F (900°C) / h	2.1	3.5	5.0
1742°F (950°C) / h	1.9	3.2	4.6
Height / " / mm	7.9 200	9.8 250	11.8 300
Width / " / mm	14.9 378	15.7 398	17.6 448
Length / " / mm	22.8 580	23.6 600	25.6 650
Weight / lb. / kg	108.0 49	125.7 57	147.7 67

Need a thermal barrier to suit your application? Tell us your requirements, and if it's possible, we'll design and manufacture it for you! We are constantly developing and looking forward to any new challenge.

High pressure proof stainless steel compression fittings protect against oil ingress and provide stress relief for the thermocouples



Heat sinks with very high thermal capacity and gas tight seals allow use in vacuum or pressure applications up to 20 bar.



Max. operating temperature 1000 °C / 1832 °F

The PhoenixTM TS12 Series Oil Quench System, uses a multi-channel, high temperature data logger protected by a thermal barrier which uses a two part insulation system. The inner thermal barrier is completely sealed to prevent oil contaminating the data logger. The outer insulation layer provides additional heat protection in the furnace, but is sacrificial during the oil quench. The system is designed not only to go through the complete heat treatment cycle including the oil quench, but has enough thermal capacity to go through a wash cycle afterwards.

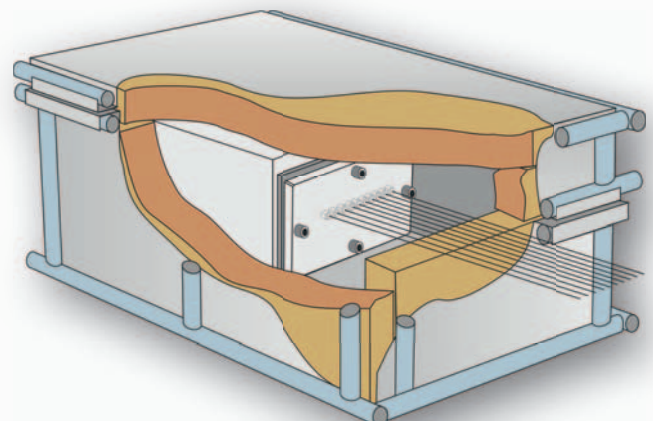

# Thermal View Plus

The easy way to get a perfect result!



**PhoenixTM**  
Phoenix Temperature Measurement

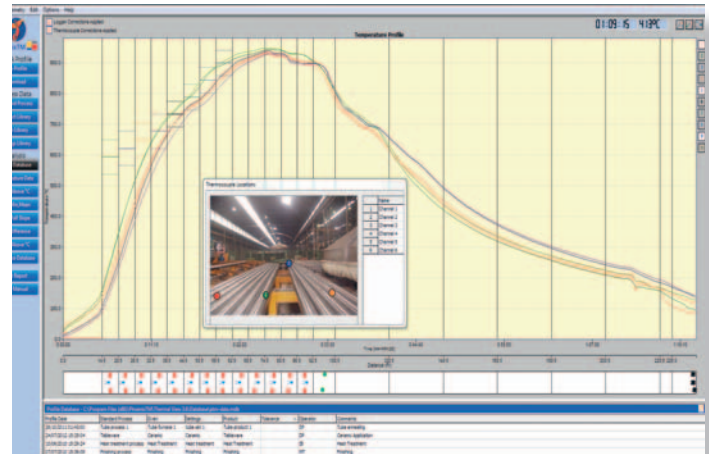
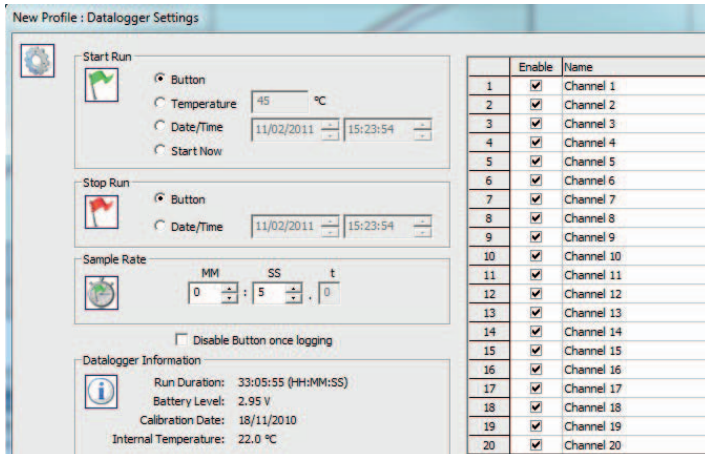

Simply enter:

- How to start the data logger
- The rate at which data is to be collected
- The number of thermocouples to be used.

For regular measurements these can be set with one mouse click or pressing the data logger start button.

The temperature profile is displayed in the graphics window of the Thermal View software. Thermocouple profiles can be switched on or off individually and you can zoom in for more detailed analysis.

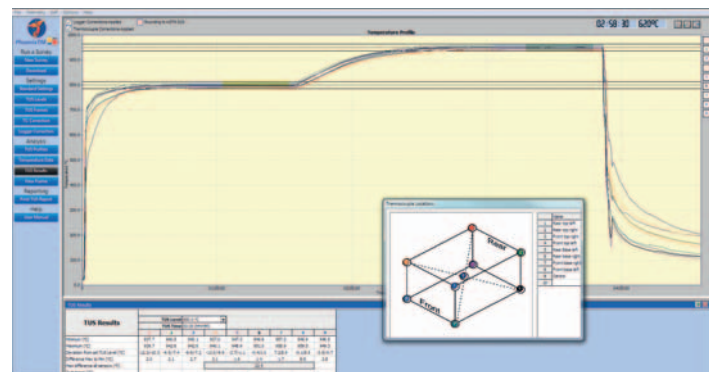
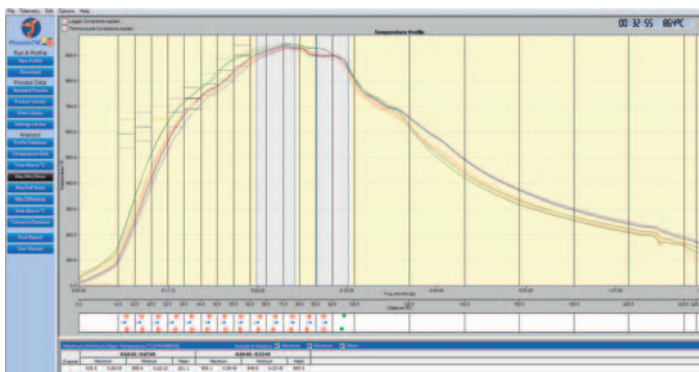

Comprehensive analysis tools are located on the left side of the screen for single click analysis and report generation. Data import and export in both .csv and PhoenixTM formats are available allowing electronic transfer of process data.

A separate software package, "Thermal View Survey" is available for surveying furnaces to AMS2750 requirements. Featuring thermocouple and data logger correction factors, user defined TUS levels and tolerances, View Frame analysis, overshoot search, data import / export, printed AMS2750 report. Contact us for a demo version!

PhoenixTM LLC  
4600 140th Avenue North,  
Suite 180,  
Clearwater  
FL 33762 USA  
Tel.: +1 (727) 608 4314



[www.phoenixtm.com](http://www.phoenixtm.com)  
[info@phoenixtm.com](mailto:info@phoenixtm.com)

 PhoenixTM Ltd, UK  
[sales@phoenixtm.com](mailto:sales@phoenixtm.com)

 PhoenixTM GmbH, Germany  
[info@phoenixtm.de](mailto:info@phoenixtm.de)